

**NIS**  
BIKES

**EFINE**

**EFINE**  
TECH MANUAL





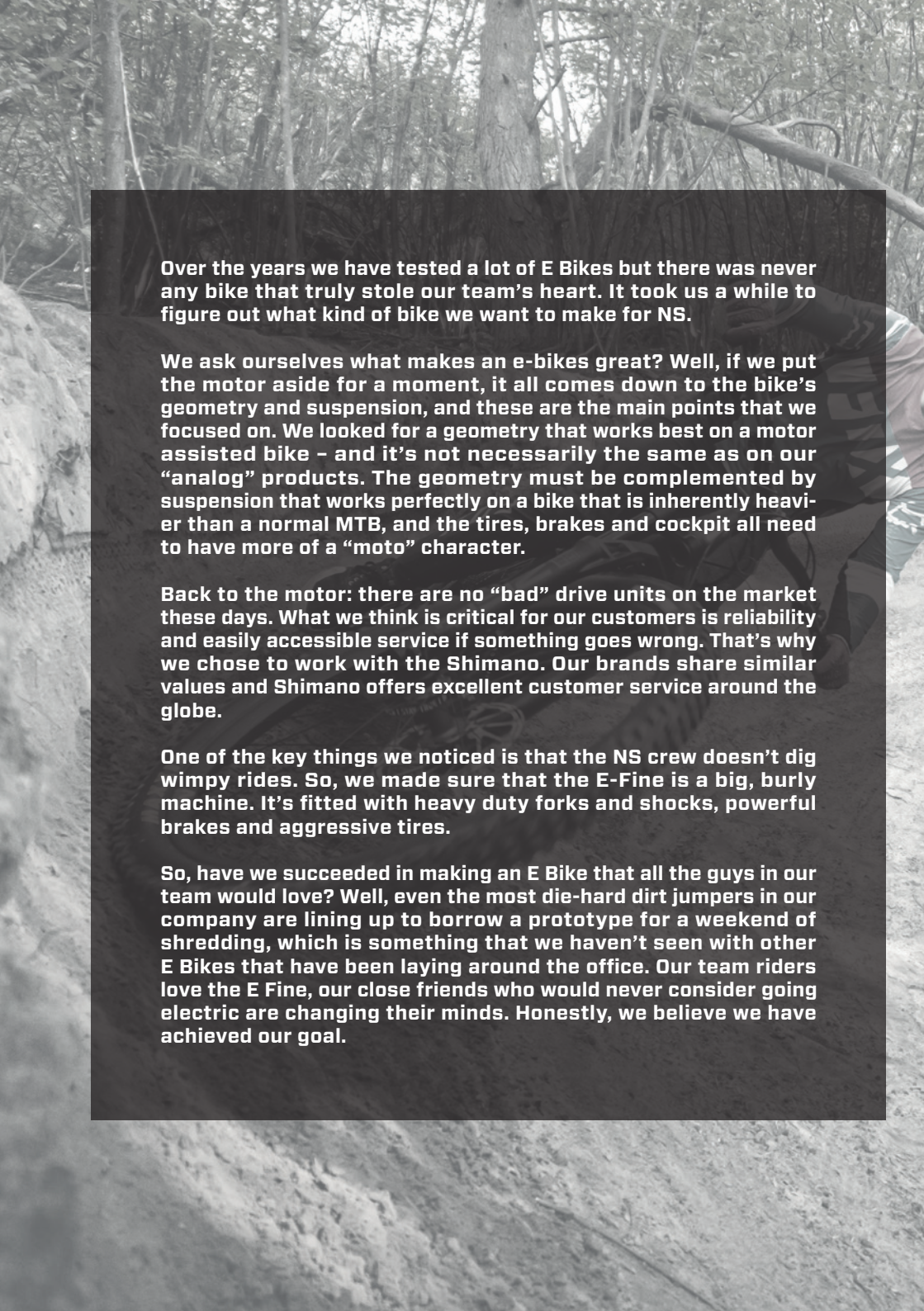

**Over the years we have tested a lot of E Bikes but there was never any bike that truly stole our team's heart. It took us a while to figure out what kind of bike we want to make for NS.**

**We ask ourselves what makes an e-bikes great? Well, if we put the motor aside for a moment, it all comes down to the bike's geometry and suspension, and these are the main points that we focused on. We looked for a geometry that works best on a motor assisted bike – and it's not necessarily the same as on our “analog” products. The geometry must be complemented by suspension that works perfectly on a bike that is inherently heavier than a normal MTB, and the tires, brakes and cockpit all need to have more of a “moto” character.**

**Back to the motor: there are no “bad” drive units on the market these days. What we think is critical for our customers is reliability and easily accessible service if something goes wrong. That's why we chose to work with the Shimano. Our brands share similar values and Shimano offers excellent customer service around the globe.**

**One of the key things we noticed is that the NS crew doesn't dig wimpy rides. So, we made sure that the E-Fine is a big, burly machine. It's fitted with heavy duty forks and shocks, powerful brakes and aggressive tires.**

**So, have we succeeded in making an E Bike that all the guys in our team would love? Well, even the most die-hard dirt jumpers in our company are lining up to borrow a prototype for a weekend of shredding, which is something that we haven't seen with other E Bikes that have been laying around the office. Our team riders love the E Fine, our close friends who would never consider going electric are changing their minds. Honestly, we believe we have achieved our goal.**





- 4 WARNINGS AND IMPORTANT INFORMATION**
- 5 GENERAL RIDING INFORMATION**
- 6 TECHNICAL SHEET / SPECS**
- 6 SPECIAL NOTE FOR EBIKES**
- 7 GEOMETRY METRIC**
- 8 GEOMETRY IMPERIAL**
- 9 FLIP-CHIP SETTING**
- 10 EXPLODED VIEW**
- 11 REPLACEMENTS**
- 13 SPARE PARTS**
- 13 SUSPENSION SETTINGS**
- 13 REAR WHEEL MOUNTING**
- 13 FRAME SIZE RECOMMENDATIONS**
- 14 TIGHTENING TORQUE**
- 15 REMOVING BATTERY**
- 16 MAINTENANCE & PERIODICAL SAFETY CHECKS**
- 17 NS BIKES WARRANTY**
- 18 DECLARATION OF CONFORMITY**
- 19 PROOF OF PURCHASE - WARRANTY CARD**

## WARNINGS AND IMPORTANT INFORMATION

**ATTENTION:** Please read this manual carefully. It contains important safety information!

**WARNING:** Extreme riding is a very dangerous sport; it requires an amazing amount of skill. By engaging in this type of activity, you are accepting the risk of possible injury or even death. Even the best bike will not help you land a clean trick if you lack the skills. Even the best protective gear will not guarantee complete safety. Remember that in this kind of riding, you can only trust your own abilities and you must accept the inherent risk. While riding you can reach significant speeds and therefore face significant hazards and risks. Inspect your bicycle and equipment carefully and be sure that it is in perfect condition before each ride. If possible consult with area site personnel, expert riders and race officials on conditions and equipment advisable. Always wear appropriate safety gear, including an approved full face helmet, full finger gloves, body armour, bright, visible clothing that is not so loose that it can be tangled in the bicycle or objects at the side of the road or trail, shoes that will stay on your feet and will grip the pedals (make sure that shoe laces cannot get into moving parts, and never ride barefoot or in sandals). Always use protective eyewear, to protect against dirt, dust and bugs.

**WARNING:** Some of the service procedures require specialist tools and good mechanical skills. Therefore, to minimize the risk of serious or even fatal accidents, maintenance and assembly work on your bike should be carried out by an authorized bicycle workshop.

**IMPORTANT NOTICE:** This manual is not intended as a comprehensive use, service, repair or maintenance manual. Please consult your dealer for advice and your dealer may also be able to refer you to classes, clinics or books on bicycle use, service, repair or maintenance.

**WARNING:** The frame box contains instructions for components made by third parties. You must study these carefully and follow the directions before riding your bike. Make sure you read and follow the suspension set up and service instruction manual provided by the manufacturer. If the instruction manual has not been provided, please contact your dealer or the manufacturer.

**WARNING:** Failure to maintain, check and properly adjust the suspension system may cause suspension malfunction, in result of which you may lose control and fall.

**WARNING:** Introducing changes in the suspension adjustment can alter the handling and braking characteristics of your bicycle. It is forbidden to change the suspension adjustment unless you are thoroughly familiar with the suspension system manufacturer's instructions and recommendations; you should always check for changes in the handling and braking characteristics of the bicycle after the suspension has been adjusted by taking a careful test ride in a safe area.

**WARNING:** As with all mechanical components, the frame is subjected to wear and high stresses. Different materials and components may react to wear or stress fatigue in different ways. If the design life of a component has been exceeded, it may suddenly fail possibly causing injuries to rider. Any form of crack, scratches or change of colour in highly stressed areas indicate that the life of the component has been reached and it should be replaced.

## GENERAL RIDING INFORMATION

Riding a bicycle can be dangerous. You must keep this in mind and be cautious at all times.

See and be seen. Use lights and reflective clothing in low light conditions.

Always wear a helmet when riding. It can save your life.

Always conduct a pre-ride check (detailed information can be found further in this manual).

Never ride the bicycle if you observe any technical problems or have any doubts about the proper functioning of any elements in the bicycle.

Keep the bike clean and well maintained.

Carry a pump, spare inner tube, patch kit, and a basic tool kit - you may need this in the case of a flat tire or other common mechanical problem that is usually easy to fix if you have the right tools. Ask your dealer for advice on this issue.

If your bicycle is equipped with gears, you can choose a gear combination that is most comfortable for the riding conditions. Gears will allow you to maintain a constant rate of pedaling. Use lower gears for going uphill and higher gears for going downhill. Ease up on your pedaling pressure when you shift gears. Ask your dealer to give you more advice on this issue.

Be careful with the brakes - they can be powerful and if activated too aggressively, may cause a crash. You should spend some time to get a better feel of the brakes on a side road or empty parking lot before the first ride. Avoid riding too fast, especially downhill. It is easy to lose control of the bicycle and crash at high speeds, and also you will find it very difficult to slow down especially if the hill is steep.

If your bike has been equipped with suspension, the increased speed you may develop will also increase the risk of injury. For example, front of the bike may dive on the suspension fork while hard braking. You can easily lose control and fall if you are not prepared for this. Please, learn how to operate your suspension system safely.

Thanks to the suspension the wheels can follow the terrain better, which improves control and comfort. This improved capacity may provide opportunity for riding faster, but you should be careful not to mistake the enhanced capabilities of the bicycle for your own riding skills. Improving skills takes time and practice.

Protect your bike from theft. Purchase a lock and never leave your bike unlocked while unattended, even if you are planning to be away from it for just a few minutes.

## TECHNICAL SHEET / SPECS

### EFINE

**rear wheel travel:** 160mm / 150mm

**recommended fork travel:** 160-180mm

**frame material:** AL6061-T6 + AL6066-T6

**rear shock:** 205x65mm / 205x62.5mm

**mounting hardware:** 20 x 8 mm, trunion

**cable routing:** semi-internal

**head tube:** tapered 1.5 IS (IS 42 / IS 52)

**headtube length:** S : 120mm, M : 120mm, L : 130mm

**fits forks** with standard 1-1/8" or tapered 1.5 - 1-1/8"

**hub spacing** 148 x 12mm, NS axle included

**post-mount** direct 180mm disc brake mount,

**max rotor size:** up to 200mm

**biggest chainring:** up to ~38t

**rear derailleur:** removable hanger included

**seat post/clamp:** 31.6mm / 34.9

stealth cable route in seat tube for dropper post

**maximum tire size recommended:** 27,5" x 2,5", depends on tire manufacturer

## SPECIAL NOTE FOR E-BIKES

Electric bikes, also known as e-bikes or pedelecs are bicycles equipped with an electric pedal assist drive system. An e-bike IS NOT a moped or motorcycle. The drive system provides the power only while you are pedalling. The amount of power transferred by the drive unit depends on the pedalling force and chosen assistance level. When you stop pedalling, the drive system disengages. Also, in all assist levels, the drive system will cut off as the bike reaches the maximum allowable speed of 25km/h. When the speed drops below that, and the pedals are turning, the system will re-engage automatically.

**WARNING:** Do not modify the bicycle drive system/ in any way for any reason. Doing so can result in severe damage, faulty or dangerous operating conditions, or violation of local laws. Dealers and owners must not change, alter, or modify in any way the original components of the bicycle or drive-assist system (e.g. the specified sizing of the attached gear ratios (front/rear chain rings) ). Any modifications may make the bike dangerous to the rider and / or other road users. Use only specified manufacturer drive-assist service and replacement parts.

**WARNING:** Only use the battery pack and charger recommended by the drive manufacturer. Do not use other batteries or chargers. Do not use the charger to charge other batteries.

**IMPORTANT NOTICE:** When the battery is not in use in the bicycle, its transportation is subject to hazardous materials regulation. Special packaging and labelling requirements may exist. Contact local authorities for specific requirements. Never transport a damaged battery. Insulate battery contacts before packaging. Package battery inside a shipping container to prevent damage. The battery must be removed before flying. The air carrier may request special handling of the battery.

**GEOMETRY METRIC**

**EFINE**

based on fork travel 170mm  
flip-chip set on LOW

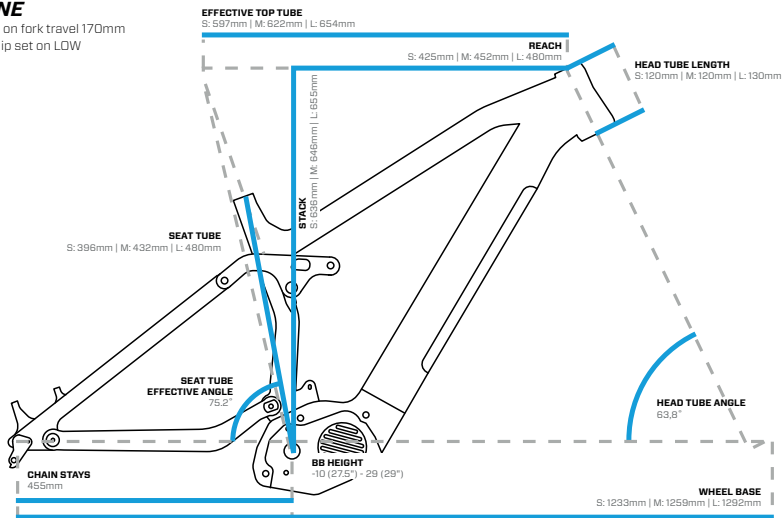

**EFINE**

based on fork travel 160mm  
flip-chip set on LOW

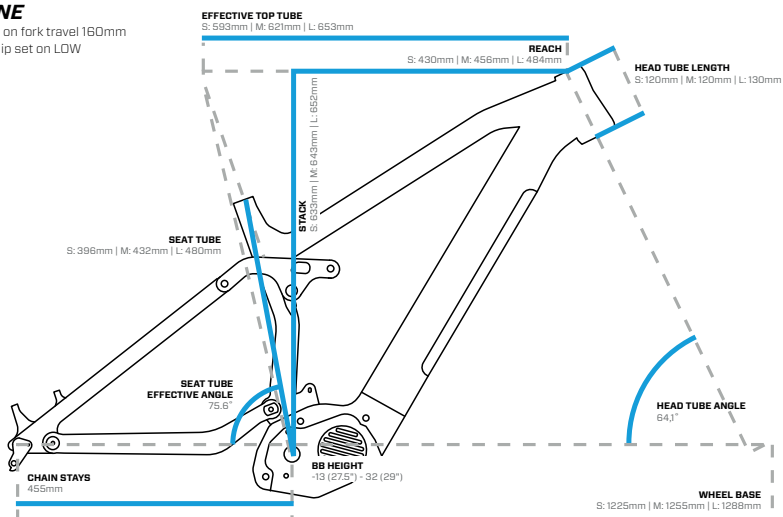

**GEOMETRY IMPERIAL**

**EFINE**

based on fork travel 170mm  
flip-chip set on LOW

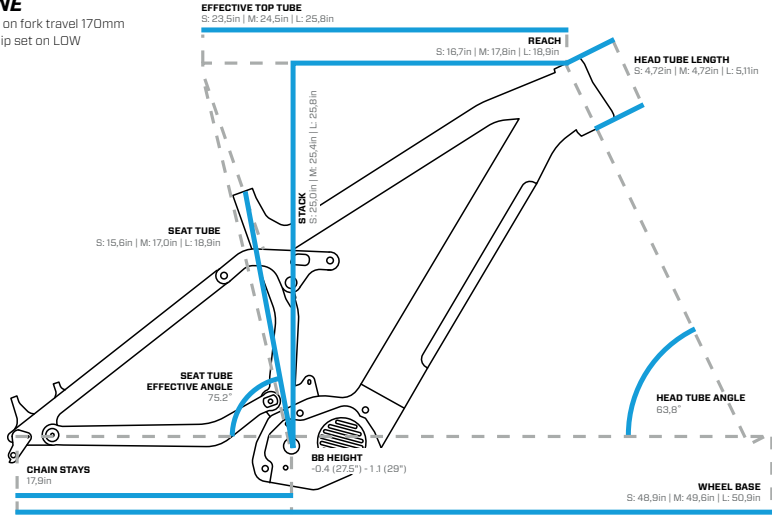

**EFINE**

based on fork travel 160mm  
flip-chip set on LOW

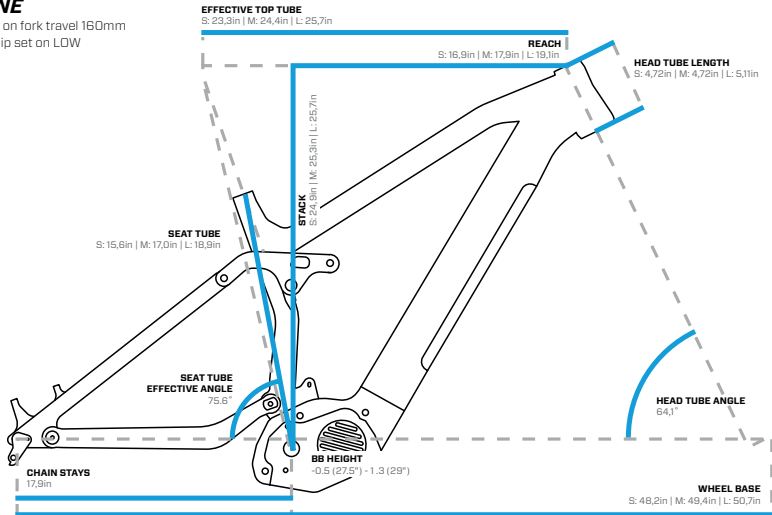



**FLIP-CHIP SETTING**

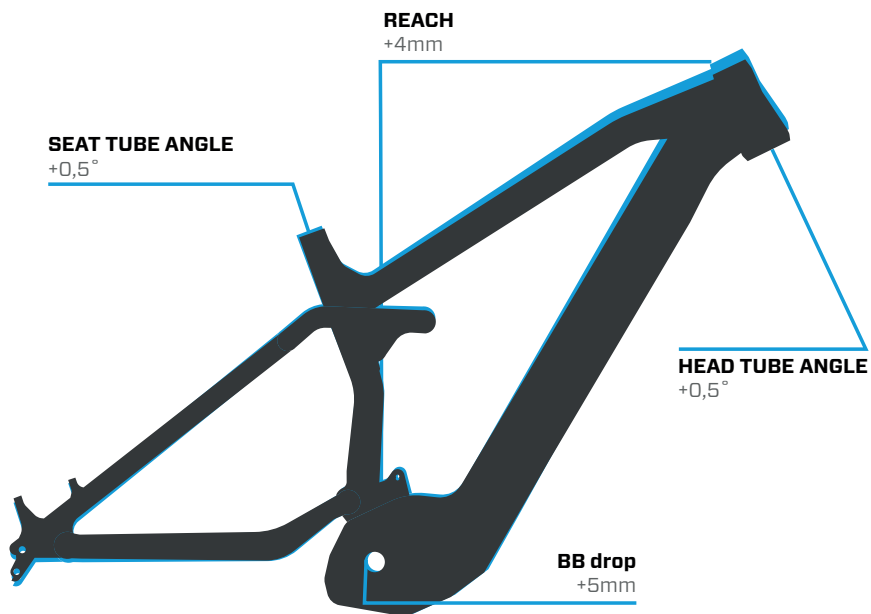

■ LOW POSITION  
FLIP-CHIP

■ HIGH POSITION  
FLIP-CHIP

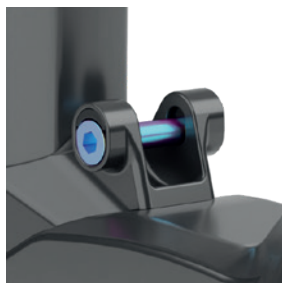

**LOW**

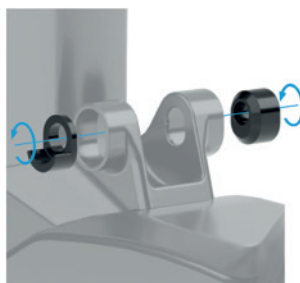

**FLIP**

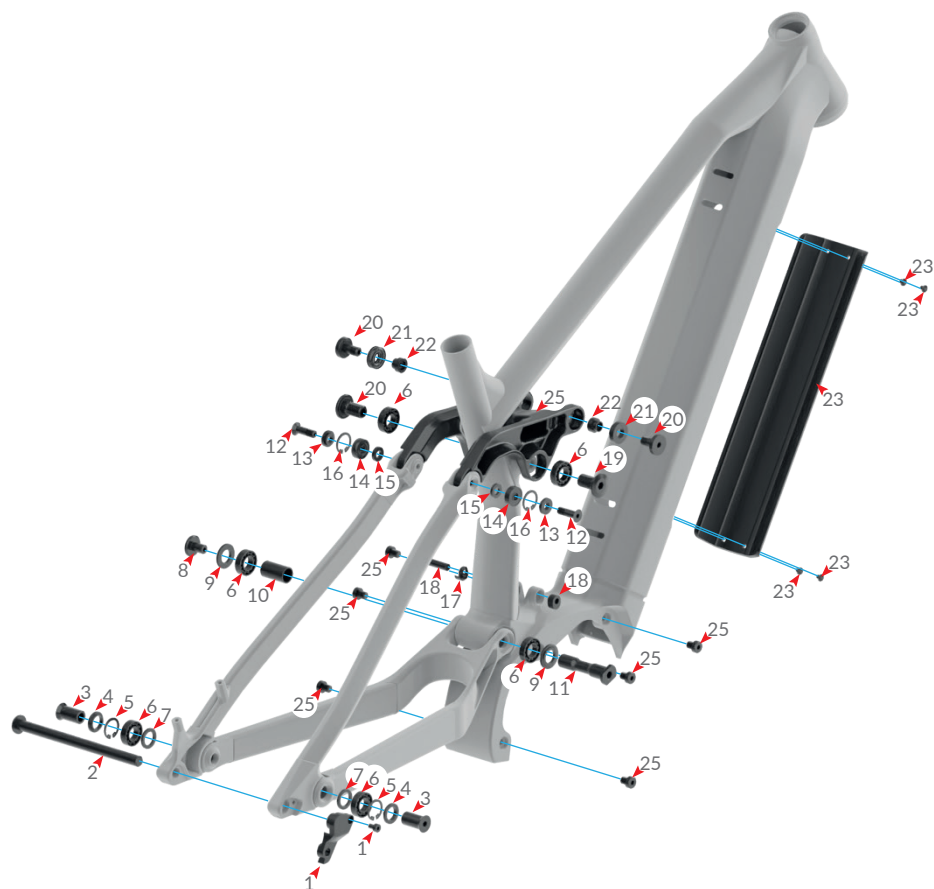

**HIGH**

**EXPLODED VIEW**

Nr	PART	CODE	Nr	PART	CODE
1	hanger + bolt	SP-140	14	SS rocker bearing	608 (Ø8*Ø22*7T) SP-150
2	axle 148x12 (174L)	SP-079	15	SS clevis inner washer	SP-077
3	horst link bolt	SP-193	16	SS clevis c-clip	SP-077
4	horst link washer	SP-193	17	flip-chip (2pcs)	SP-195
5	horst link c-clip	SP-193	18	Ti shock mount bolt (1 pc.)	SP-195
6	horst link bearing	6902-2RS (Ø15*Ø28*7T) SP-150	19	rocker arm bolt	SP-075
7	horst link washer	SP-193	20	trunion bolt	SP-163
8	main pivot bolt	SP-194	21	trunion bearing	6902-2RS(Ø15*Ø28*7T) SP-150
9	main pivot washer	SP-194	22	trunion washer	SP-150
10	main pivot spacer	SP-194	23	battery cover+bolts (4 pcs.)	SP-200
11	main pivot axle	SP-194	24	rocker arm	SP-118
12	SS clevis bolt	SP-076	25	Ti motor bolts (6 pcs.)	SP-255
13	SS clevis outter washer	SP-077			

**REPLACEMENTS**

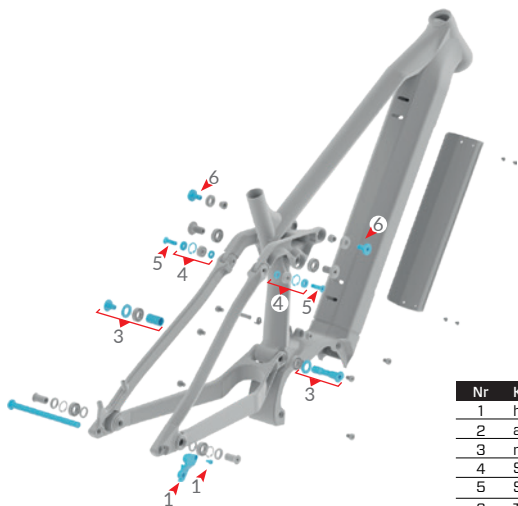

Nr	KIT	CODE
1	hanger	SP-140
2	axle 148x12 (174L)	SP-079
3	main pivot hardware	SP-194
4	SS clevis hardware	SP-077
5	SS clevis bolts	SP-076
6	Trunion bolts	SP-163

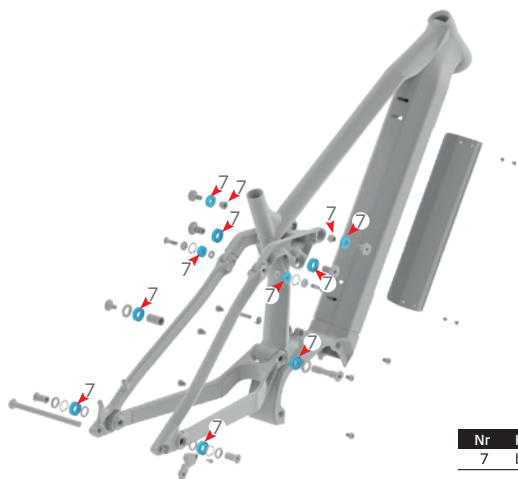

Nr	KIT	CODE
7	bearings	SP-150



**REPLACEMENTS**

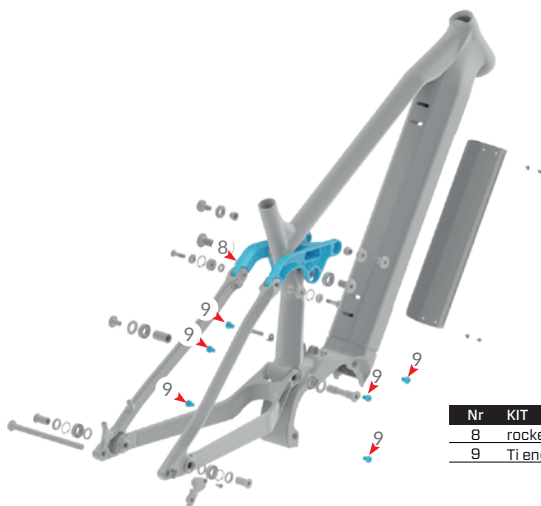

Nr	KIT	CODE
8	rocker	SP-118
9	Ti engine bolts (6 pcs.)	SP-255

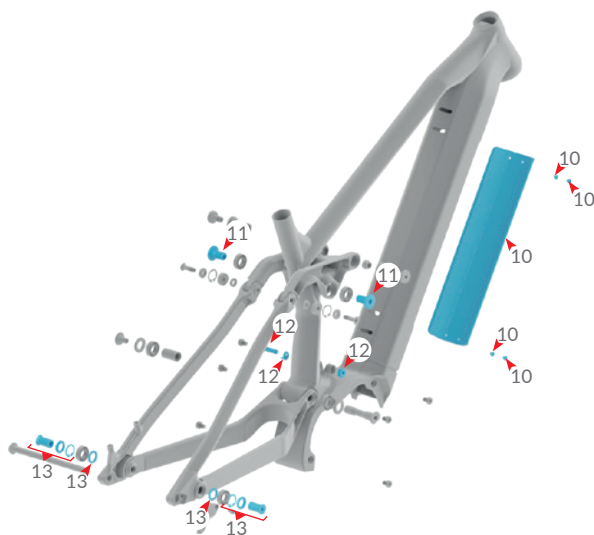

Nr	KIT	CODE
10	battery cover + bolts	SP-200
11	rocker arm bolt (2 pcs.)	SP-075
12	horst link hardware	SP-193
13	Ti shock bolt + flip-chip	SP-195

## SPARE PARTS

### ACCESSORIES:

- ChainStay Slapper protector 2 pc. (SP-208)
- seatpost clamp 34.9 (SP-144)

## SUSPENSION SETTINGS

Suspension settings are a matter of personal preference. Some riders like it plush, some like it firm. However here are some suggestions of shock settings that you can use as basic guidelines. Typically, the E-fine should run with about 20% to 30% sag. To measure sag, push the bottom-out bumper up the shock shaft until it meets the body of the shock. Gently stand up on the pedals with all your weight on the bike (fully kitted up with body armour, helmet, neck brace, hydration pack, etc. – it's important to make the situation as 'real world' as possible to give you the most accurate results) and note how far the bumper displaces

## REAR WHEEL MOUNTING INSTRUCTION

The Efine frame is compatible with 148x12 thru-axle hubs. For proper rear wheel installation please follow the instructions:

- make sure the wheel is aligned and the disc sits properly in the brake caliper
- put the wheel into the dropouts with the chain set up correctly on a cassette
- put the 12mm axle through and tighten properly with 6mm allen key

## FRAME SIZE RECOMMENDATIONS

**note on sizing:** we recommend the S size for 160 - 170cm, M size for 170 - 182cm and the L size for riders over 180cm.

## TIGHTENING TORQUE

Correct tightening forces on fasteners, nuts, bolts, screws on your bicycle are crucial. Too little force, and the fastener may not hold securely. Too much force, and the fastener can strip threads, stretch, deform or break. Either way, incorrect tightening force can result in component failure, which can cause you to lose control and fall. If in any doubt, or if any problems are found during the pre-ride check you should immediately seek professional advice from a professional bicycle mechanic.

Study the manuals of the suppliers of the suspension fork, rear shock, and other parts that come with this frame. Do not ride the bicycle until all problems have been resolved. Riding a bicycle with any defects can be a hazard to your health and life! Unless you are a very competent bicycle mechanic, do not attempt to execute any of these adjustments yourself. Seek advice at your local bicycle shop. The rear suspension bolts (rear shock and pivots) have been tightened in the factory with specific torque. In case of re-adjustment extreme care should be taken when re-tightening them.

Tightening torque for various bolts on the frame:

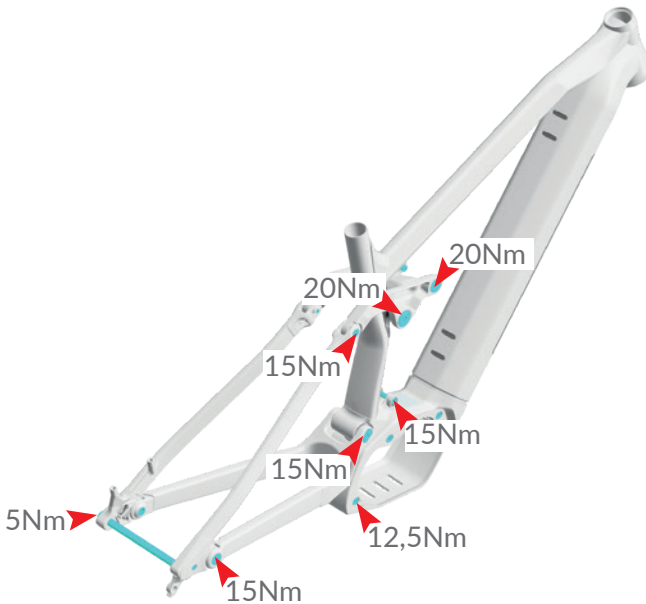

For other components please first refer to manufacturer instructions.



## REMOVING BATTERY

**1**  
Insert 4mm Hexagon wrench.

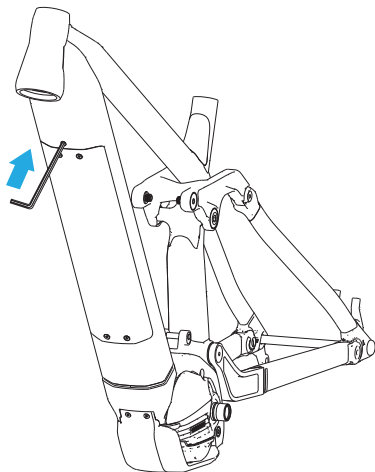

**2**  
Support the battery with your hand and turn the hexagon wrench clockwise. First ratchet is unlocked, but battery is still locked by second ratchet.

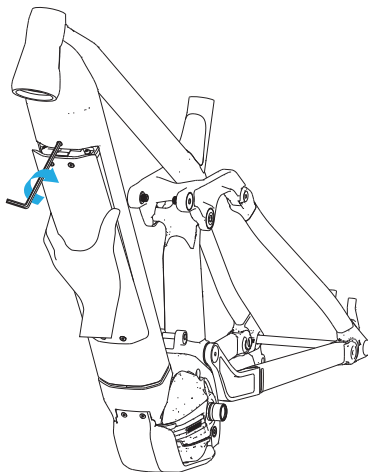

**3**  
Push ratchet button.  
Second ratchet is unlocked.

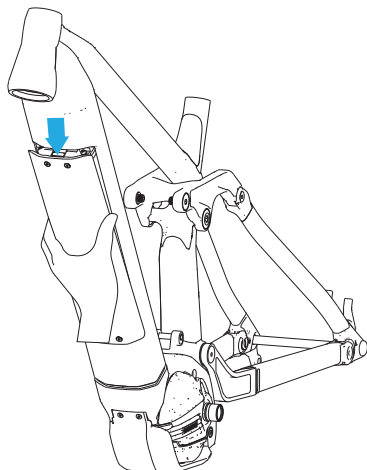

**4**  
You can remove the battery.

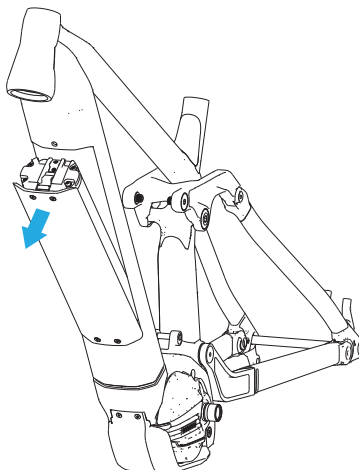

## MAINTENANCE & PERIODICAL SAFETY CHECKS

### DO NOT RIDE THE BICYCLE IF IT YOU SEE ANY DEFECTS.

Take care of your frame and you will enjoy it for a longer time. Before every ride you should always make a pre-ride check. It should include the following points: clean the frame (note that high-pressure washing may cause damage to some components on the bicycle so it should be avoided if possible) and examine it CAREFULLY for any indications of potential failures including cracks, corrosion, dents, paint peeling and any other indications of potential problems, inappropriate use or abuse. If anything suspicious is found, contact your local bike dealer for a proper inspection. These are important safety checks and very important to help prevent accidents, injury and shortened product lifespan.

### Things to check before each ride:

- all frame bolts are correctly tightened – refer to # TIGHTENING TORQUE
- wheel to frame & fork connections - this is critical for your safety. If you have axle bolts they should be tightened according to the manufacturer's specification. If you have a quick release make sure that it is set to the CLOSED position, and that there is a reasonable amount of resistance applied.
- steering system. The steering system includes: handle bar, stem, headset and fork. All elements should be connected firmly for riding safety. If you wish to make any adjustments yourself, be warned that incorrect setup can be very dangerous and we always advise you to seek professional advice for this! Check headset looseness, check stem to handlebar connection and stem to steertube connection. Check the connection between the handlebars and stem. Try pushing the handlebars up and down - there should be no movement between these two elements. Check the headset for eventual free play (stand next to the bicycle, apply the front brake and push forwards and backwards. There should be no play between the frame and fork). If any play is found contact your local bike shop. Do not attempt to make any adjustments yourself. If you are confident that you can do this yourself then adjust the steering system according to the headset/stem manufacturer instructions. All parts of the stem should be regularly checked for damage or cracks. If you find anything suspicious, contact an experienced bike mechanic immediately. A defective steering system can cause serious injury or death.
- bottom bracket connection to the frame. There should be no play between the frame and bottom bracket.
- the connection between the cranks and bottom bracket.
- the connection of the pedals to the cranks.
- chain line and chain tension.
- derailleur connection with the frame and make sure the function is proper before every ride.
- brake clamp to frame & fork connection.
- the general condition of rear shock and front fork (take special note of any cracks or deformations).
- shock / fork pressure (for air shocks). Refer to the # SUSPENSION SETTINGS and manufacturers instruction. Make sure the SAG doesn't exceed the reasonable limit. Make sure the air pressure does not exceed limits provided by shock / fork manufacturer
- clean rear shock & forks stanchion tubes.
- brake cables and their housing for kinks, rust, broken strands or frayed ends. If you notice any damage, you should ask a bicycle shop to replace the cables immediately. Damaged cables can seriously impede braking efficiency.

For information about servicing the shock and other parts like the headset mounted on the bike it is necessary to follow manufacturers instructions closely. The user manual for the additional parts are supplied in the frame box.

## NS BIKES WARRANTY

**1.** 7ANNA Group Sp. z o.o. (hereinafter on referred to as 7ANNA),

manufacturer of NS BIKES, warrants all its new bicycles against defects in materials and workmanship for a period of 2 years, paints and decals for a period of 1 year (excluding natural wear and mechanical damage).

**2.** If any defects are noticed in the bicycle, the Customer must stop using the product immediately and should report this to the dealer that sold it within 14 days. Using a damaged bicycle will void the warranty, lead to more extensive damage and may pose a serious hazard to the rider's health and life.

**3.** The warranty period starts from the day when the product is purchased by the end user (eg. private customer or rental station). This purchase must be documented with the cash receipt plus filled in warranty card (which includes the following information: date of purchase, serial number of frame, name of bike model, customer's name and name of dealer).

**4.** The warranty applies only to the original owner and is not transferable.

**5.** Claims under this warranty **MUST** be made through the dealer where the bicycle was purchased.

**6.** The bicycle should be submitted to a mandatory checkup between the 3rd and 5th week from date of purchase (or after 50km of riding) to an authorised bicycle dealer. The confirmation of this checkup should be documented in the warranty card. Failure to do this will void the warranty.

**7.** The warranty is valid only if the bicycle is sold by an authorised dealer in a ready-to-ride condition.

**8. General Warranty replacement & repairs information**

A) If a certain part of the bicycle requires replacement under this warranty, component functionally equivalent to the originals might be provided. It may not always be possible to provide parts that are identical. If a warranty claim for a painted part is granted, but this part is not available in the requested colour (either due to discontinuation of the colour line or due to out of stock situation) 7ANNA reserves the right to replace these parts with equivalent products in currently available finish.

B) If a damaged product requires repair, 7ANNA is not obliged to provide information about the repair process and its technological details. 7ANNA provides a warranty for products that have undergone repair.

C) If a repair requires a replacement of parts, that have been succeeded by a newer generation on the market, the company is not obliged to provide the updated version of components.

**9.** The warranty does not cover wear and tear of tires, chains, brake pads, bearings, cogs and chainrings. Wheel truing, lubricating, brake adjustment, drive train adjustment and other typical maintenance procedures are not covered by the warranty and must be conducted by a professional bicycle workshop at the cost of the customer. The warranty does not cover: mechanical damages to paint and decals, discoloration of the paint resulting from long-term exposure to weather conditions or aggressive cleaning chemistry used. Problems that result from excessive loads occurring during extreme riding or from incorrect riding technique. The warranty does not cover: the cost of travel or shipment to and from an authorised dealer. Such costs, if any, shall be borne by the original owner.

**10.** This warranty is void if: the warranty card is filled in incorrectly or incompletely, any modifications have been made to the bicycle by the customer, damage has been caused by external parts that have been incorrectly assembled on the bicycle, the product had not been used, maintained or repaired according to the manufacturer's instructions, the bicycle had been sold disassembled, or only partially assembled, the product was transferred to any third party.

**11.** Directions on how to deal with warranty cases shall be provided by the distributor of the product in the region where it was purchased.

**12.** The Crash Replacement Warranty covers damage resulting from crashing, or excessive loads generated by things like casing jumps or throwing the bike. Such damage won't be covered by the normal warranty, however 7ANNA offers the possibility to replace the product for 50% of the original suggested retail price under the Crash Replacement policy. The conditions for this are: Crash Replacement applies to components made by 7ANNA that are mounted in the bikes, all Rondo frames for a period of 1 YEAR from the date of purchase, 7ANNA reserves the right to deny Crash Replacement without further explanations, Crash Replacement does not apply to parts damaged in other situations than in riding (for example Crash Replacement will not cover a part that has been damaged during shipping), Crash Replacement does not apply to complete bikes. It only applies to components made by 7ANNA that are mounted in the bikes.

**13.** This limited warranty does provide the original owner with certain legal rights and recourse and the original owner may possess other rights or recourse, depending on the state, jurisdiction, country, or province. Please be informed that this is a final statement of the 7ANNA and all the remedies available to the original owner are stated herein. 7ANNA does not allow or authorise any entity (including authorised dealers) to extend any other express or implied warranties on its behalf. An original owner agrees that 7ANNA's liability under this warranty under no circumstances shall be greater than the original purchase price. In no event shall 7ANNA be liable for incidental or consequential damages. All other remedies, obligations, liabilities, rights, warranties, express or implied, arising from law or otherwise, including (but not limited to) any claimed implied warranty of merchantability, any claimed implied warranty arising from course of performance, course of dealing or usage of trade, and any claimed implied warranty of fitness, are disclaimed by 7ANNA and waived by the original owner. Some states, jurisdictions, countries, and provinces do not allow some or all the limitations set forth herein, or the exclusion or limitation of incidental or consequential damages. If any provision is found unenforceable, only that provision shall be stricken, and all others shall apply.



**DECLARATION OF CONFORMITY**

**We, the undersigned:**

**Manufacturer:**

7ANNA Group Sp. z o.o.

Address, Potokowa 20d, 80-283, 80-237 Gdansk, Poland

**Declare the following apparatus:**

**Products name:**

E-bikes

**Brand and Model name:**

NS Bikes E-fine 0

NS Bikes E-fine 1

NS Bikes E-fine 2

**Hereby we confirm above products compliance with the European directive of EU Machinery Directive 2006/42/EC & CE.**

**Below standards were tested and passed:**

EMC Directive 2014/30/EC

PN-EN ISO 12100:2011-03

PN-EN 15194:2017-12

**The original document is located in the headquarters,  
7ANNA Group, Potokowa 20D, 80-283 Gdansk**



**PROOF OF PRUCHASE - WARRANTY CARD****FRAME MODEL:** \_\_\_\_\_**FRAME SERIAL NUMBER:** \_\_\_\_\_**SHOCK SERIAL NUMBER (IF ANY):** \_\_\_\_\_**PRICE:** \_\_\_\_\_**DATE OF PURCHASE:** \_\_\_\_\_

*I cetrify that I am acquainted with the actual specification of the bicycle (this can be slightly different than that published by the distributor)*

**BUYER'S SIGNATURE:** \_\_\_\_\_**DEALER'S SIGNATURE:** \_\_\_\_\_**DEALER'S STAMP**

*manufactured by: 7ANNA GROUP sp. z o.o., ul. Potokowa 20d, 80-283 Gdańsk, POLAND*

*Always wear a helmet when riding. It will not make you deathproof, but will increase your chances to avoid serious injury if you crash (and you WILL crash). A broken leg can be fixed A broken brain cannot! Even if you see some of our riders without a helmet, it's only because they are complete idiots!*

[www.nsbikes.com](http://www.nsbikes.com)  
[info@nsbikes.com](mailto:info@nsbikes.com)

