

Living Easy



Colore: **blue**

Specifiche tecniche



Aluminium, sizes: S-M / L-XL



Promax Solve ST 925 hydraulic 2P,
180mm disc



Yamaha PW S2,
Torque/Coppia: 75Nm



GBC 29"



Fantic, Lithium Ion, 36 Volt, 630Wh



Vittoria E-Randonneur



Suntour XCR34, travel 100mm



Selle Italia Max S5 Superflow



Sram SX, 12V, 11-50

(*) FANTIC MOTOR si riserva il diritto di modificare le caratteristiche tecniche elencate, senza alcun obbligo di preavviso.
Tutte le immagini sono inserite a scopo illustrativo. I prodotti possono subire modifiche.



Indice

Control, handling, exclusivity, mileage.

69



(*) FANTIC MOTOR si riserva il diritto di modificare le caratteristiche tecniche elencate, senza alcun obbligo di preavviso. Tutte le immagini sono inserite a scopo illustrativo. I prodotti possono subire modifiche.

Living City

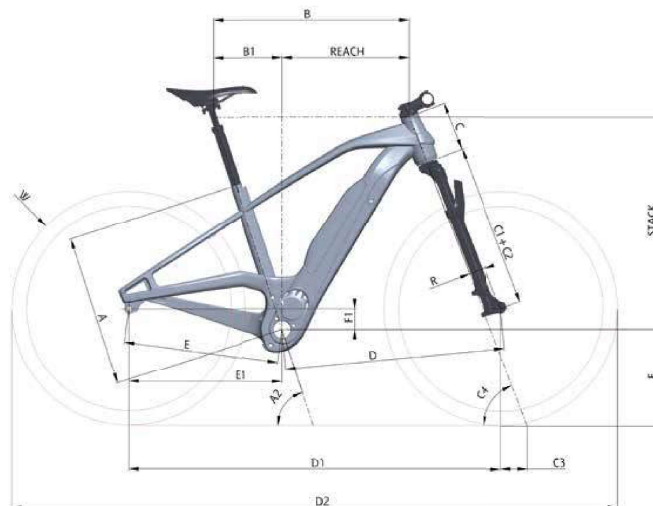

Motore	Yamaha PW S2, Torque/Coppia: 75Nm
Batteria	Fantic, Lithium Ion, 36 Volt, 630Wh
Display	Display B Yamaha
Telaio	Aluminium, sizes: S - M - L
Forcella	RST Volant, travel 50mm
Cambio	Enviolo City
Pedivelle	FSA
Freno ant.	Promax Solve ST 925 hydraulic 2P, 180mm disc
Freno post.	Promax Solve ST 925 hydraulic 2P, 180mm disc
Pneumatici	Vittoria E-Randonneur
Ruote	GBC 29" (M-L) - 27.5" (S)
Mozzo ant.	GBC, 110mm Boost
Mozzo post.	GBC, 148mm Boost
Manubrio	GBC 700mm, Rise 20mm
Attacco manubrio	GBC 70mm
Sella	Selle Italia T3 Flow
Reggisella	Promax Suspended Ø30.9
Pedali	Aluminium
Luce anteriore	Busch Muller
Luce posteriore	Trelock
Lucchetto	Abus
Note	(*)

Misure	S	M	L
A	430	460	500
A2	72	72	72
B	575	600	625
B1	201	201	207
Reach	374	399	418
Stack	618	618	637
W	27,5"	28"	28"
C	150	150	170
C1	2	2	2
C2	460	460	460
C3 Trail	84,15	92,2	92,2
C4	69	69	69
R	44	44	44
D	637,5	662	688
D1	1101	1126	1152,5
D2	1785	1854	1880,5
E	471,2	471,2	471,2
E1	467	467	467
F	279	301	301
F1	63	63	63
Lever	170	170	170
Stem	100	100	100
Bar	700	700	700
Regg.	350	350	350

(*) FANTIC MOTOR si riserva il diritto di modificare le caratteristiche tecniche elencate, senza alcun obbligo di preavviso. Tutte le immagini sono inserite a scopo illustrativo. I prodotti possono subire modifiche.



@fanticbikes



Fantic Bikes



Fantic Bikes



Fantic Motor



@fanticmotor_official

fantic.com

FANTIC

Fantic,
disegniamo,
progettiamo
ed assembliamo
bici elettriche
ad alte
prestazioni.

Fantic Motor S.P.A.
Via Tarantelli, 7
31030 Dossan di Casier (TV) Italy
info@fanticmotor.it
fantic.com