

XTF 1.5

Variante colore:
silver

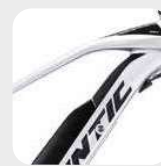

Colore: **yellow**

Specifiche tecniche



Aluminum, sizes: S - M - L



Sram SX Eagle



Brose S-Alu,
Torque/Coppia: 90 Nm



Sram Level 2 Piston disc brake



Fantic, Lithium Ion, 36 Volt, 630Wh



Rodi TRYP30



RockShox Recon Silver RL 150mm



Pirelli Scorpion ProWall



RockShox Deluxe Select



Selle Italia Model-X
Comfort Superflow 145

(*) FANTIC MOTOR si riserva il diritto di modificare le caratteristiche tecniche elencate, senza alcun obbligo di preavviso.
Tutte le immagini sono inserite a scopo illustrativo. I prodotti possono subire modifiche.



(*) FANTIC MOTOR si riserva il diritto di modificare le caratteristiche tecniche elencate, senza alcun obbligo di preavviso. Tutte le immagini sono inserite a scopo illustrativo. I prodotti possono subire modifiche.

XTF 1.5

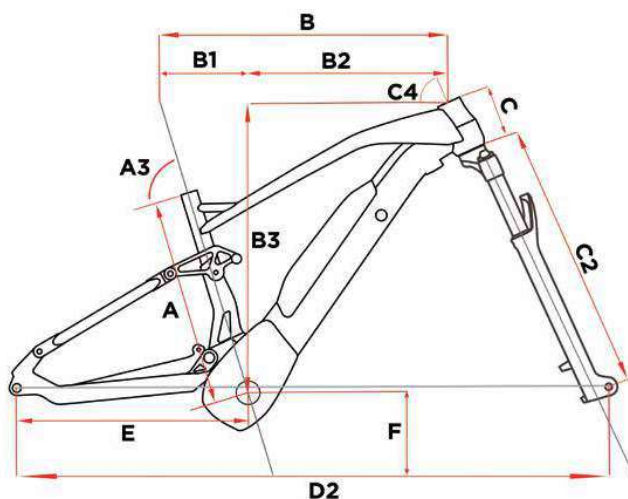

Motore	Brose S-Alu, Torque/Coppia: 90 Nm
Batteria	Fantic, Lithium Ion, 36 Volt, 630Wh
Display	Brose All Round
Telaio	Aluminum, sizes: S - M - L
Forcella (**)	RockShox Recon Silver RL 150mm
Ammortizzatore	RockShox Deluxe Select
Corona	Sram 34t
Pedivelle	Miranda
Deragliatore	Sram SX
Comandi cambio	Sram SX Eagle
Cassetta	Sram SX, 12V, 11-50
Catena	Sram SX
Freno ant.	Sram Level 2 Piston disc brake
Freno post.	Sram Level 2 Piston disc brake
Disco ant.	SramCenterLine, 200mm - 6Hole
Disco post.	SramCenterLine, 180mm - 6Hole
Pneumatici ant.	Pirelli Scorpion ProWall 29"x 2.4
Pneumatici post.	Pirelli Scorpion ProWall 29"x 2.4
Ruote	Rodi TRYP30
Manubrio	Promax ø31,8 760mm Rise 20mm
Attacco manubrio	Promax 60MM ±6° ø31,8
Reggisella	Promax teles. SP-2038 Ø 30,9, S 80mm / M-L 100mm
Sella	Selle Italia Model-X Comfort Superflow 145
Note	(*)
(**) Alternative fork / forcella alternativa Suntour Auron 35	

Misure	S	M	L
A	390	430	490
A3	73	73	73
B	575	602	627
B1	166	169	174
B2	407	433	453
B3	615,8	625,0	641,5
C	105	115	130
C2	567	567	567
C4	66	66	66,5
D1	1193	1224	1244
E	472	472	472
F	358	358	358

(*) FANTIC MOTOR si riserva il diritto di modificare le caratteristiche tecniche elencate, senza alcun obbligo di preavviso. Tutte le immagini sono inserite a scopo illustrativo. I prodotti possono subire modifiche.



@fanticbikes



Fantic Bikes



Fantic Bikes



Fantic Motor



@fanticmotor_official

fantic.com

FANTIC

Fantic,
disegniamo,
progettiamo
ed assembliamo
bici elettriche
ad alte
prestazioni.

Fantic Motor S.P.A.
Via Tarantelli, 7
31030 Dossan di Casier (TV) Italy
info@fanticmotor.it
fantic.com